

Installation Instructions for VSC-XHI Spring Isolators

Introduction

Thank you for using Vibro/Dynamics Isolators. We recommend that you completely study this information before you start the installation.

Leveling Instructions

The isolators should be installed in accordance with the following procedure:

1. Ideally, the Vibro/Dynamics Isolators should be set on a dry, flat and level concrete surface with a trowel or brushed finish. The surface does not have to be smooth, ground or polished, but there should not be any holes, joints, cracks, or bumps in the floor surface directly under the isolator. Remove all loose concrete, chips, oil, grease and water from the foundation surface that will support the isolator.
2. The Vibro/Dynamics Isolators should be examined to ensure they are of the correct size, and if appropriate, the positions for different sizes should be located in accordance with recommendations and drawings.
3. The bottom of the machine feet should be clean and flat in the area in contact with the top of the isolator to obtain a uniform bearing surface. In some cases, it may be necessary to scrape, file or grind the bottoms of the machine feet. After cleaning, inspect the machine legs and feet, and repair or replace them if they are broken or cracked.
4. After the Vibro/Dynamics Isolators are in position, the machine base should be rough leveled and aligned using jacks or steel blocks and shims at an elevation just above the top of the isolator. (See Figure 1).

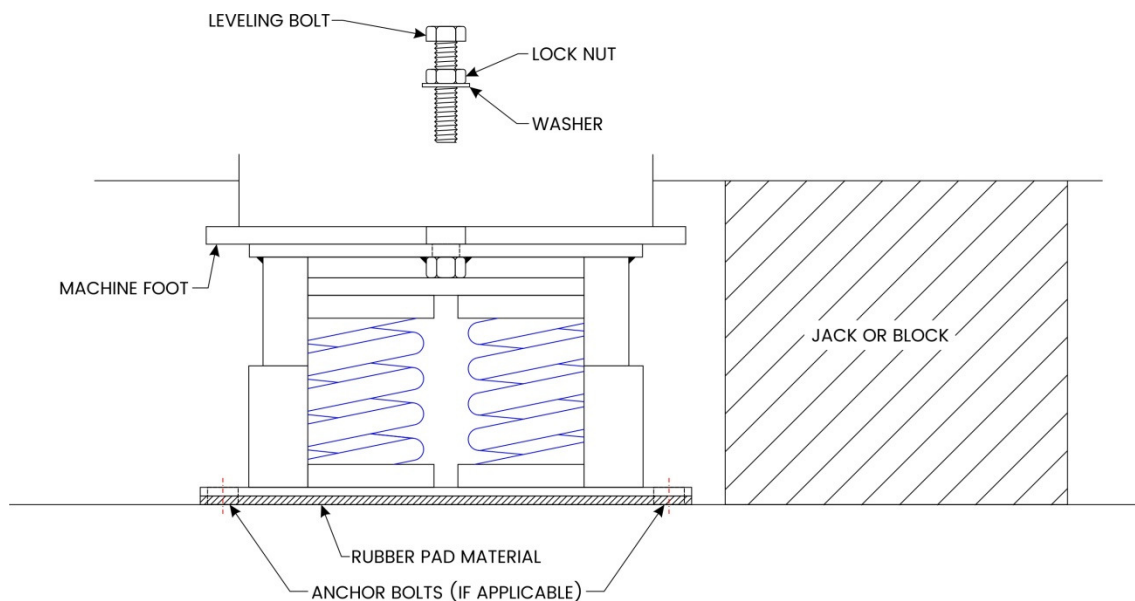

Figure 1

TECHNICAL BULLETIN: M/L-713

5. At this stage isolator anchor bolts can be loosely fitted to maintain isolator positions during final lowering of the machine base, but it is important these do not strain the isolator in any direction. (Anchor bolts supplied by customer).
6. The Isolator Leveling Bolt should be inserted through the foot and into the isolator. Thread the bolt into the isolator by hand until it touches the top of the bearing plate. (See Figure 2).

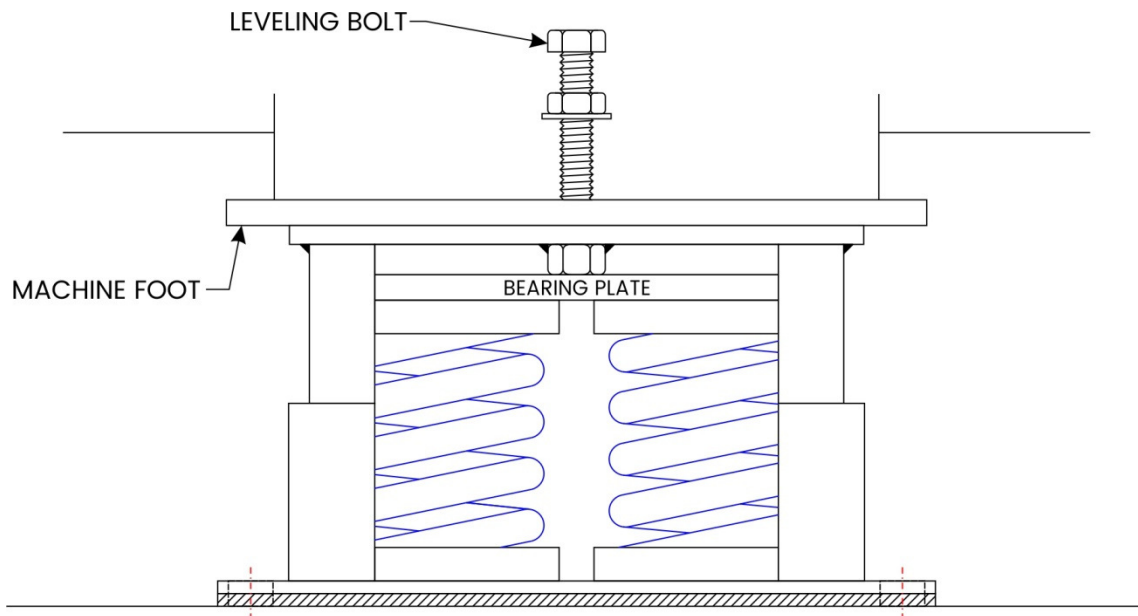

Figure 2

7. Remove jacks or blocks and slowly lower the machine onto the isolators, keeping the machine as level as possible.
8. Additional leveling and elevation adjustments will likely be needed. Raise machine as evenly as possible and make adjustments using the Leveling Bolt.
9. Tighten isolator locknuts, and leveling is complete.

For further information, contact: VIBRO/DYNAMICS LLC

© Copyright 2020, Vibro/Dynamics LLC, All Right Reserved